

River
palms

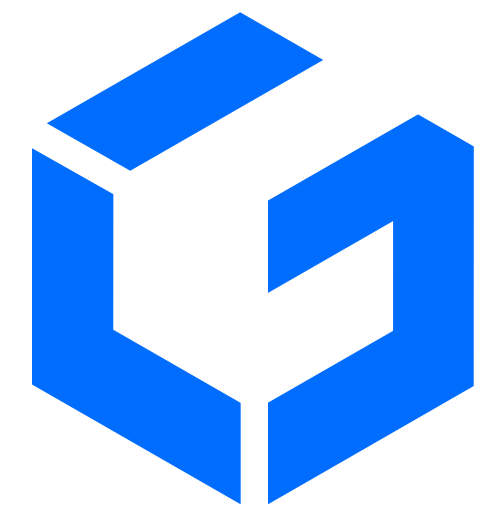

**Londoño
Gómez**

**INSPIRAMOS
UNA TARDE
CON AMIGOS**

**EL APARTAMENTO
QUE INSPIRA**



POLO DE DESARROLLO DE BARRANQUILLA

En Buenavista, estrato 6

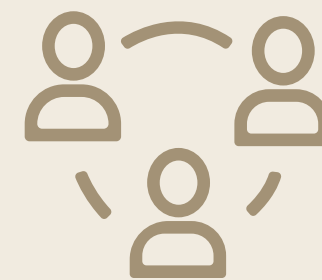

Ubicado a 3 min de los Centros Comerciales Buenavista 1 y 2, Plaza del Parque y Mall Plaza Rodeado de parques lineales • Zonas verdes y senderos • Con fácil acceso y circulación vial Cercanía a puntos de interés como Universidades, Colegios; Centros empresariales y de salud

- Polo de desarrollo y valorización.

UBICACIÓN



BUENAVISTA

BOULEVARD
DE BUENAVISTA

SALA DE VENTAS

River
palms



SALA DE VENTAS

River
palms





"Este plano contiene ilustraciones que son interpretación artística, no comprometen a la sociedad constructora. Su diseño definitivo corresponde a los planos aprobados por la curaduría urbana. *Áreas aproximadas."



Urbanismo



SALA DE VENTAS
River
palms



Planta de Suplencia Total



Zonas Comunes

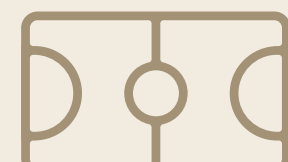
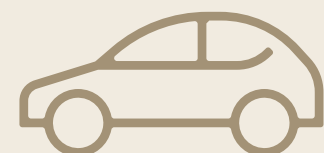

Gran lobby con sala de espera · Car lobby · Gimnasio · Zona zen-meditación · Coworking & coffee station
Cancha fútbol 5 · Playground · Cicloparqueadero · Pérgola con zona BBQ
Piscina lúdica · Piscina para adultos · Zona Pet



Imagen sujeta a cambios









INSPIRAMOS UN CAFÉ EN LA MAÑANA

River
palms

2 Apartamentos
modelos

Apartamentos de
72 a 120 m²





FOTO APARTAMENTO MODELO 72* m²



FOTO APARTAMENTO MODELO 72* m²

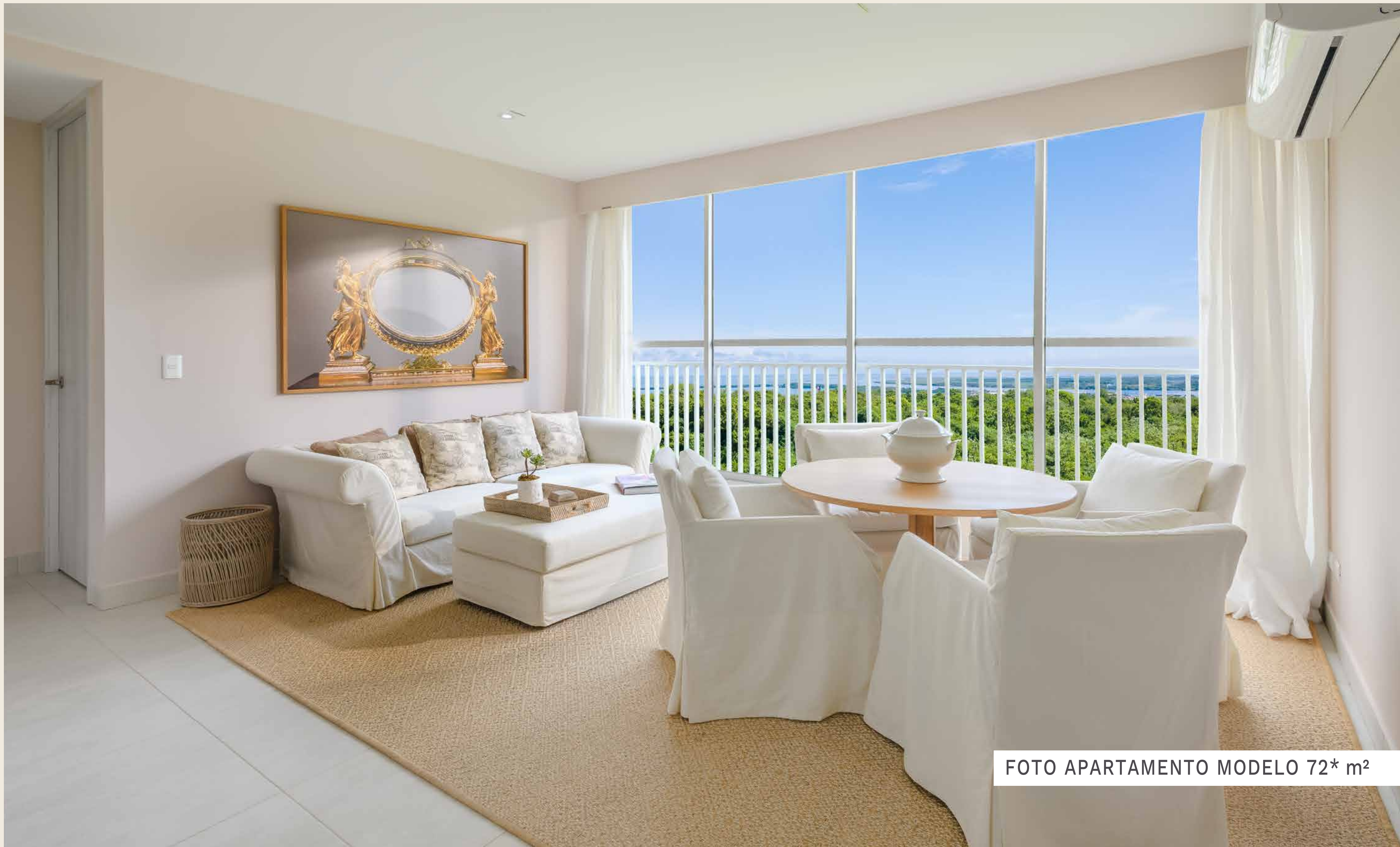

FOTO APARTAMENTO MODELO 72* m²



FOTO APARTAMENTO MODELO 72* m²



FOTO APARTAMENTO MODELO 72* m²



FOTO APARTAMENTO MODELO 120* m²

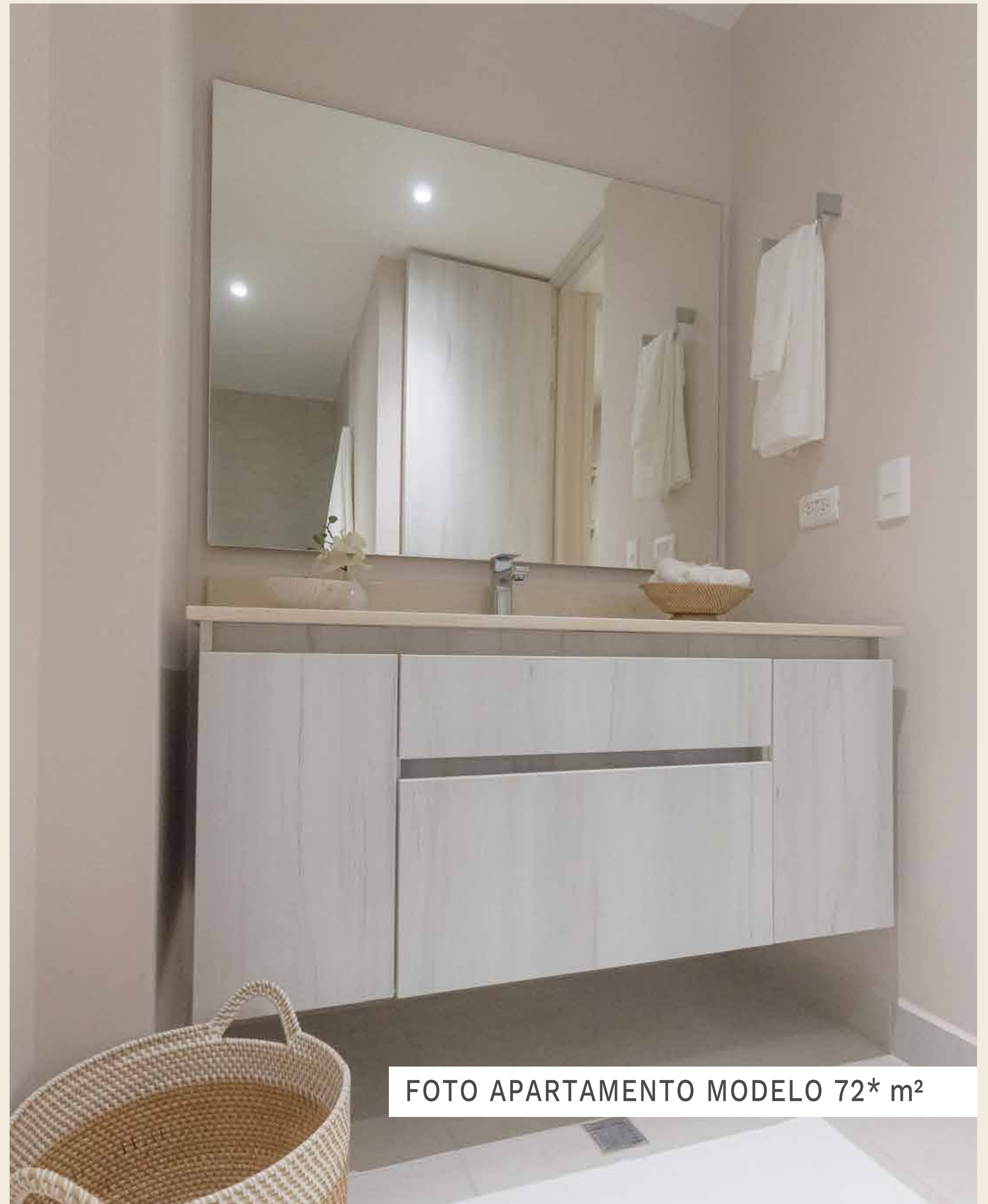

FOTO APARTAMENTO MODELO 120* m²

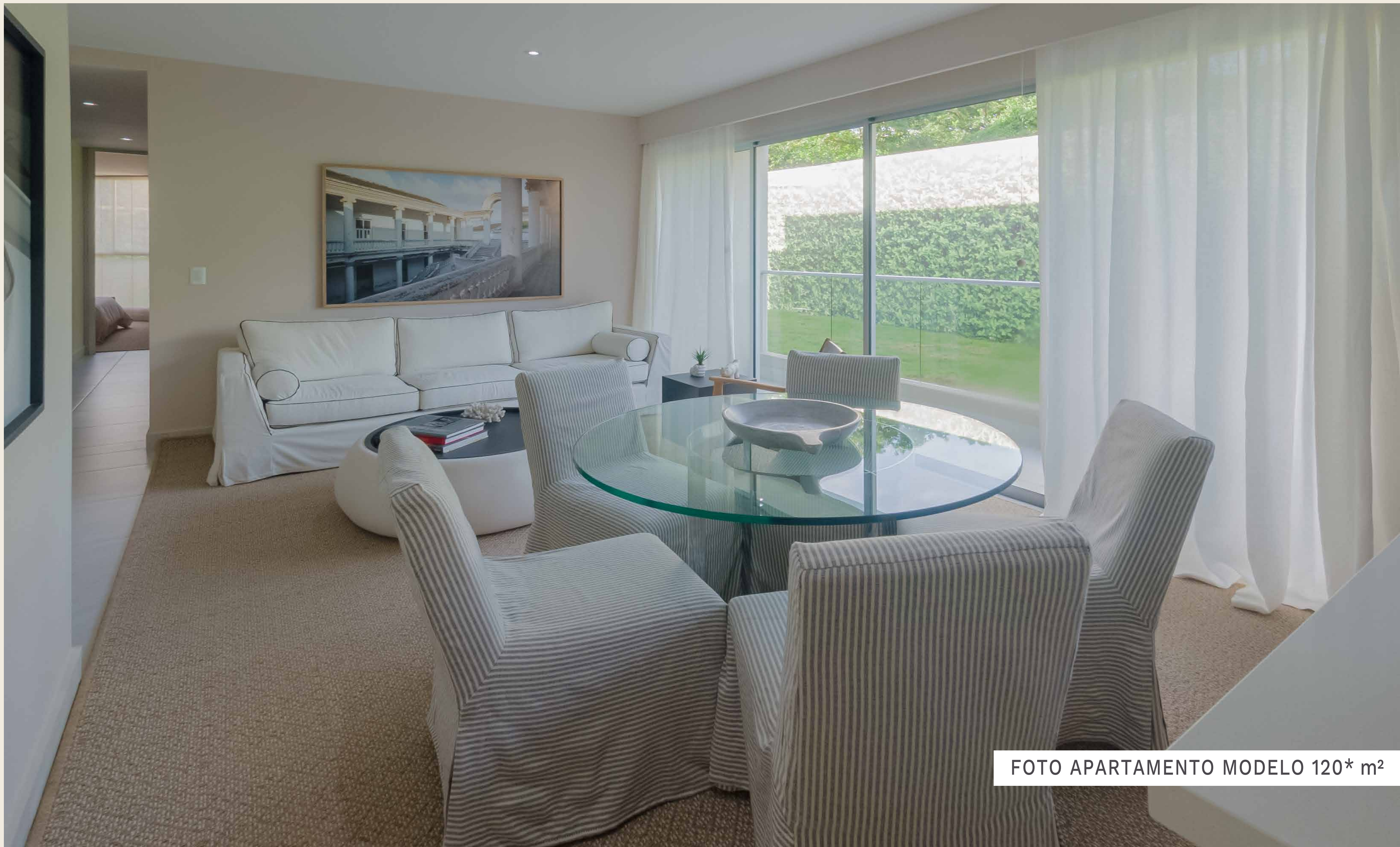

FOTO APARTAMENTO MODELO 120* m²



FOTO APARTAMENTO MODELO 120* m²



Torre 1 | PLANTA TIPO

TORRE 1

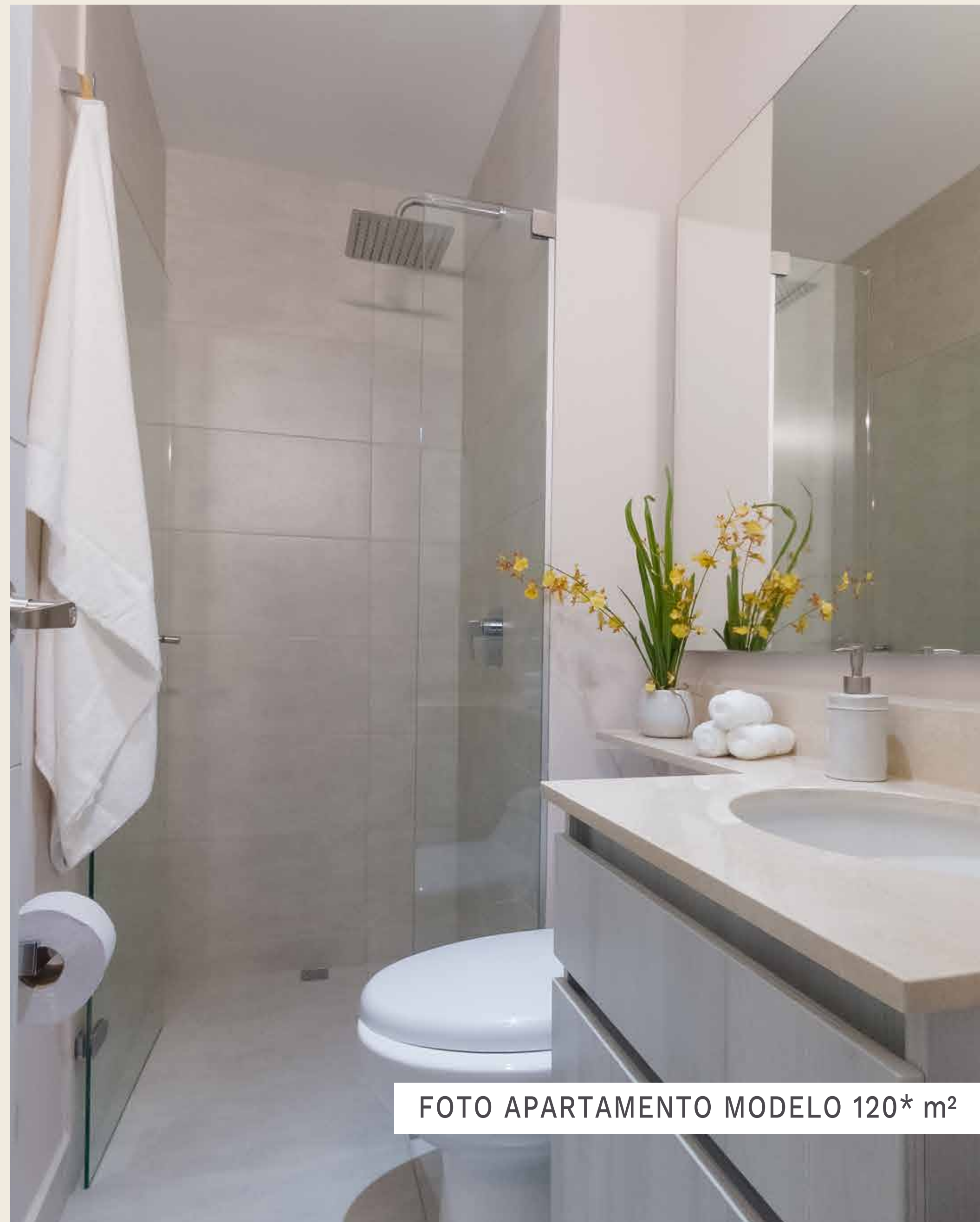
TIPO F | Serie 2
Área construida: 120.53* m²
Área privada: 112.13* m²

TIPO C | Serie 3
Área construida: 72.94* m²
Área privada: 68.27* m²

TIPO E | Serie 4
Área construida: 102.73* m²
Área privada: 95.83* m²

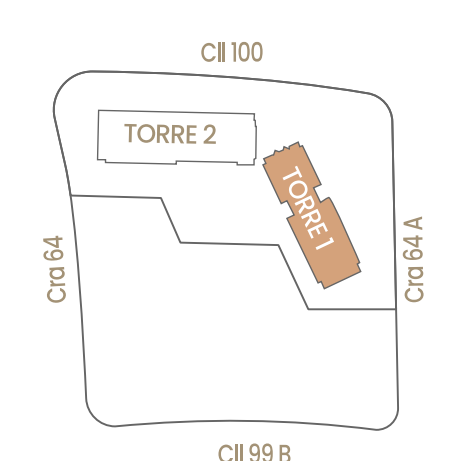

TIPO F | Serie 1
Área construida: 120.33* m²
Área privada: 111.16* m²

TIPO C | Serie 6
Área construida: 72.2* m²
Área privada: 67.33* m²

TIPO E | Serie 5
Área construida: 102.73* m²
Área privada: 94.82* m²

“Este plano contiene ilustraciones que son interpretación artística, no comprometen a la sociedad constructora. Su diseño definitivo corresponde a los planos aprobados por la curaduría urbana. *Áreas aproximadas.”



TIPO F

Torre 1 | Series 1 y 2

Área construida: 120,33* m²

Área privada: 111,16* m²

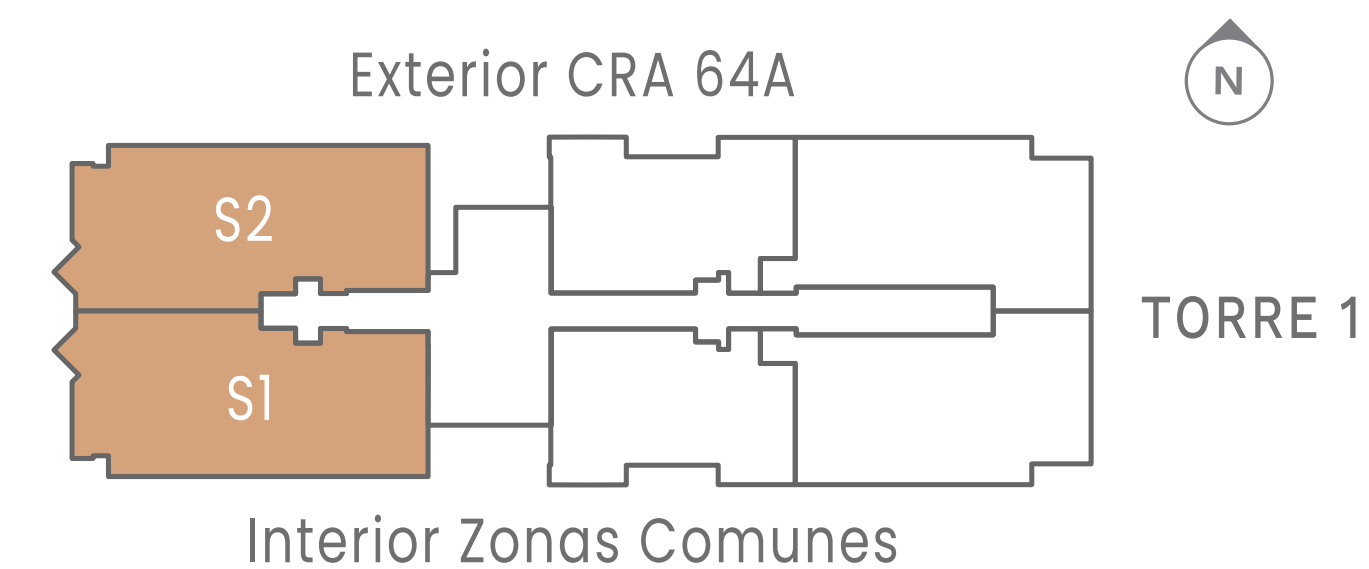



TIPO C

Torre 1 | Series 3 y 6

Área construida: 72,20* m²

Área privada: 67,33* m²

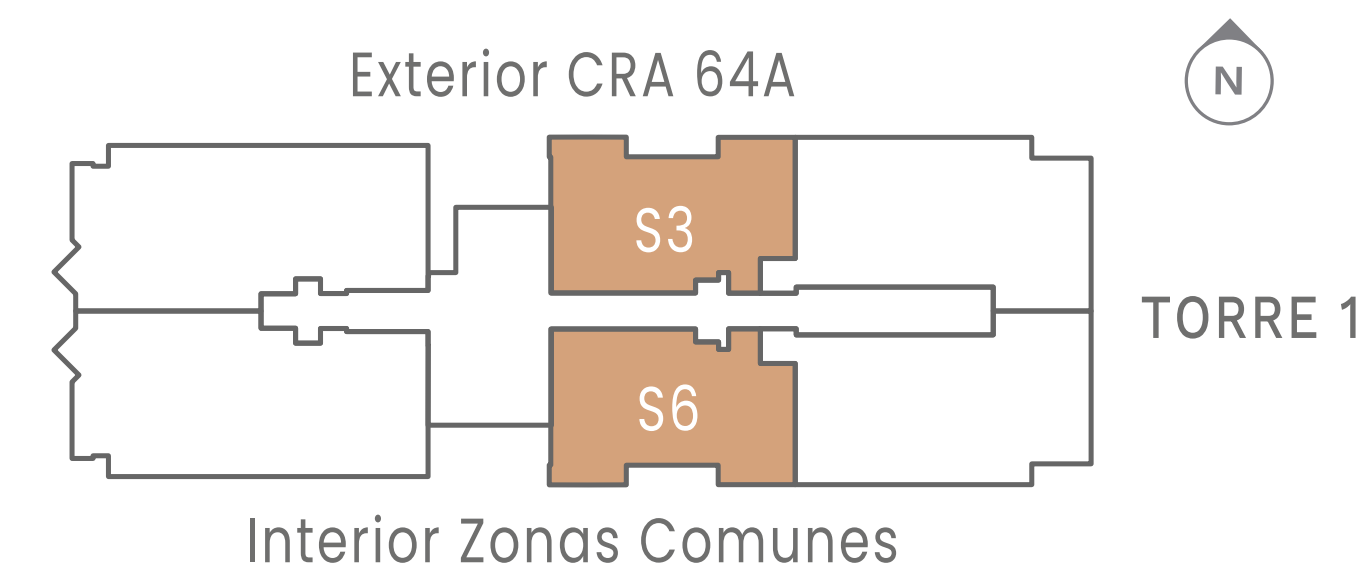



TIPO E
Opción Alcoba de Servicio
Torre 1 | Series 4 y 5
Área construida: 102,73* m²
Área privada: 95,08* m²

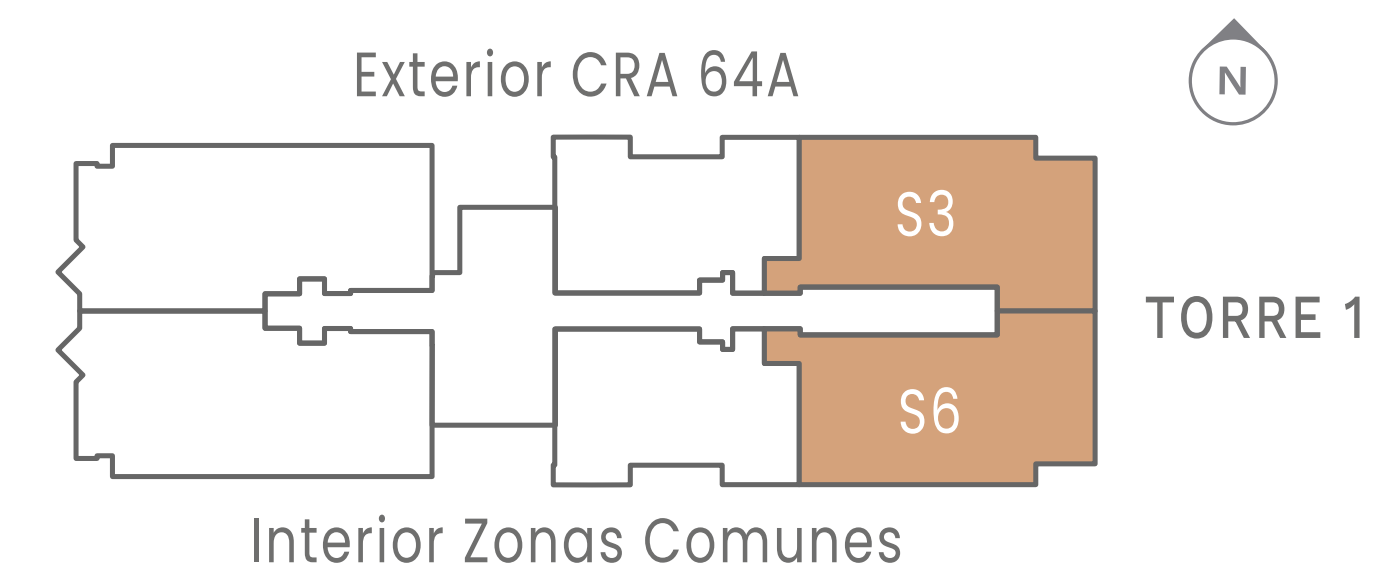

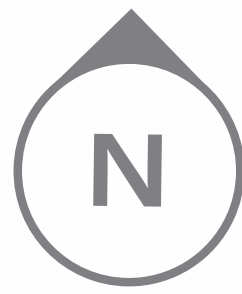

TIPO E
Opción Estudio
Torre 1 | Series 4 y 5
Área construida: 102,73* m²
Área privada: 95,08* m²

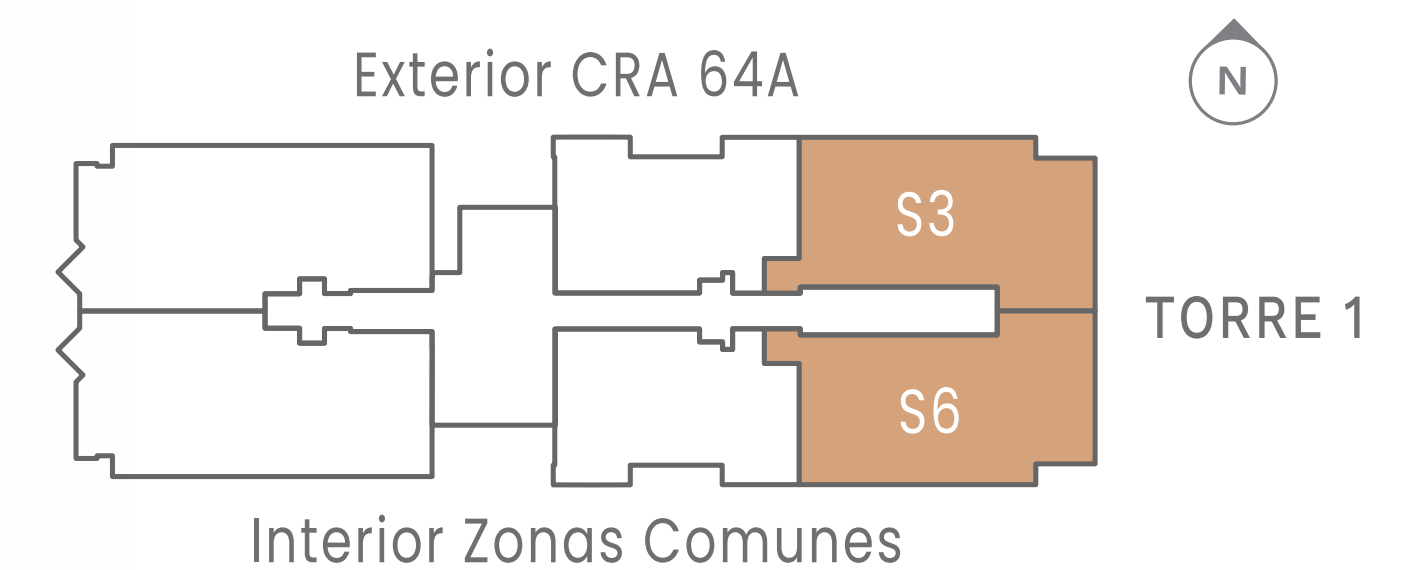



Torre 2 | PLANTA TIPO

TORRE 2

TIPO E | Serie 9
Área construida: 102.84* m²
Área privada: 95.83* m²

TIPO D | Serie 10
Área construida: 93.08* m²
Área privada: 88.09* m²

TIPO B | Serie 11
Área construida: 69.05* m²
Área privada: 64.95* m²

TIPO A | Serie 12
Área construida: 83.76* m²
Área privada: 78.35* m²

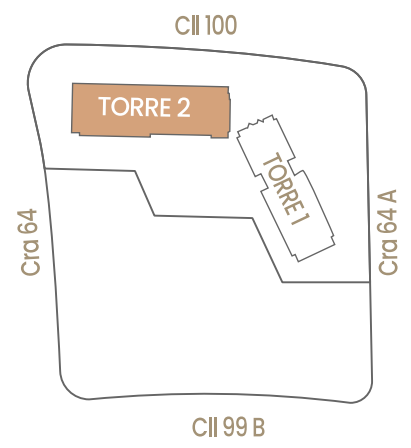

TIPO E | Serie 9
Área construida: 102.80* m²
Área privada: 94.82* m²

TIPO D | Serie 7
Área construida: 93.08* m²
Área privada: 88.09* m²

TIPO B | Serie 14
Área construida: 69.05* m²
Área privada: 64.95* m²

TIPO A | Serie 13
Área construida: 83.68* m²
Área privada: 77.58* m²

*Este plano contiene ilustraciones que son interpretación artística, no comprometen a la sociedad constructora. Su diseño definitivo corresponde a los planos aprobados por la curaduría urbana. *Áreas aproximadas.*



ACCESO



TIPO A
Opción Balcón
Torre 2 | Series 12 y 13
Área construida: 83,76* m²
Área privada: 78,35* m²

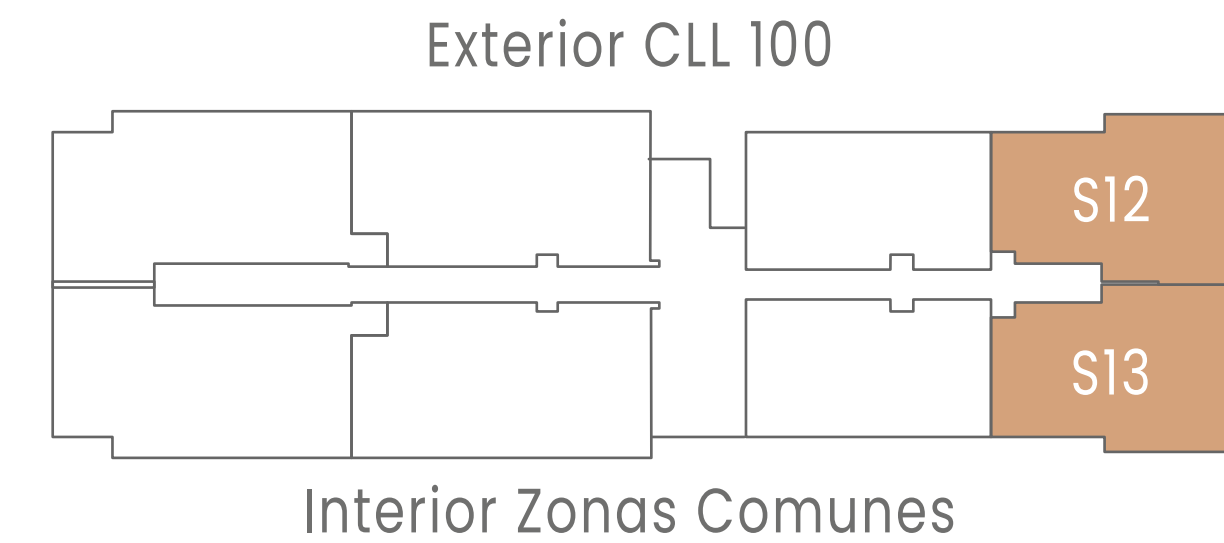



ACCESO



TIPO A
Opción French Window
Torre 2 | Series 12 y 13
Área construida: 83,76* m²
Área privada: 78,35* m²

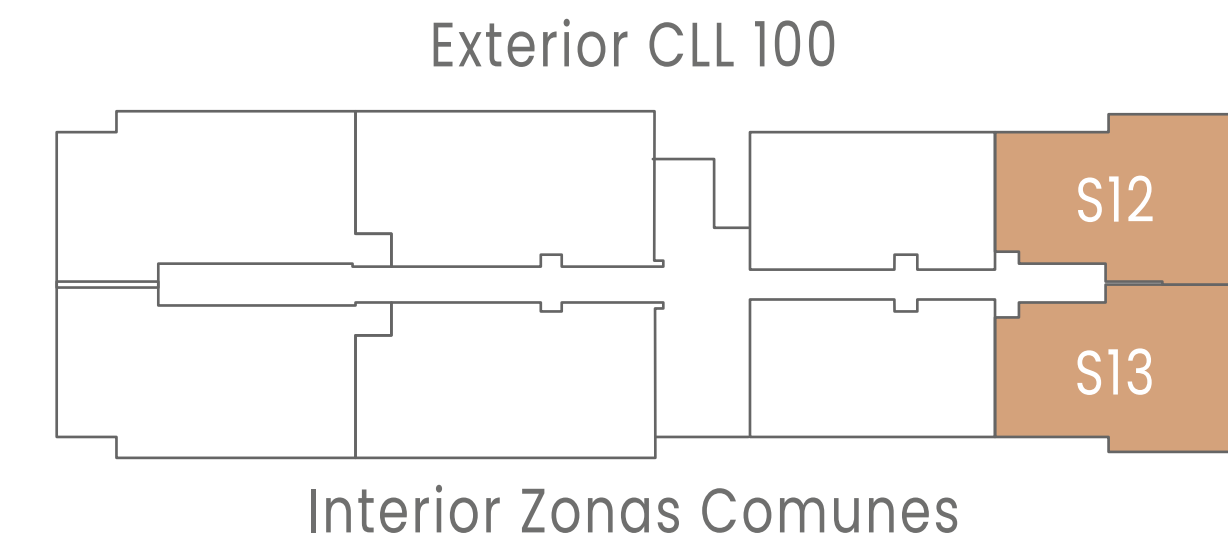



TIPO A
Opción Alcoba de Servicio
Torre 2 | Series 12 y 13
Área construida: 83,76* m²
Área privada: 78,35* m²

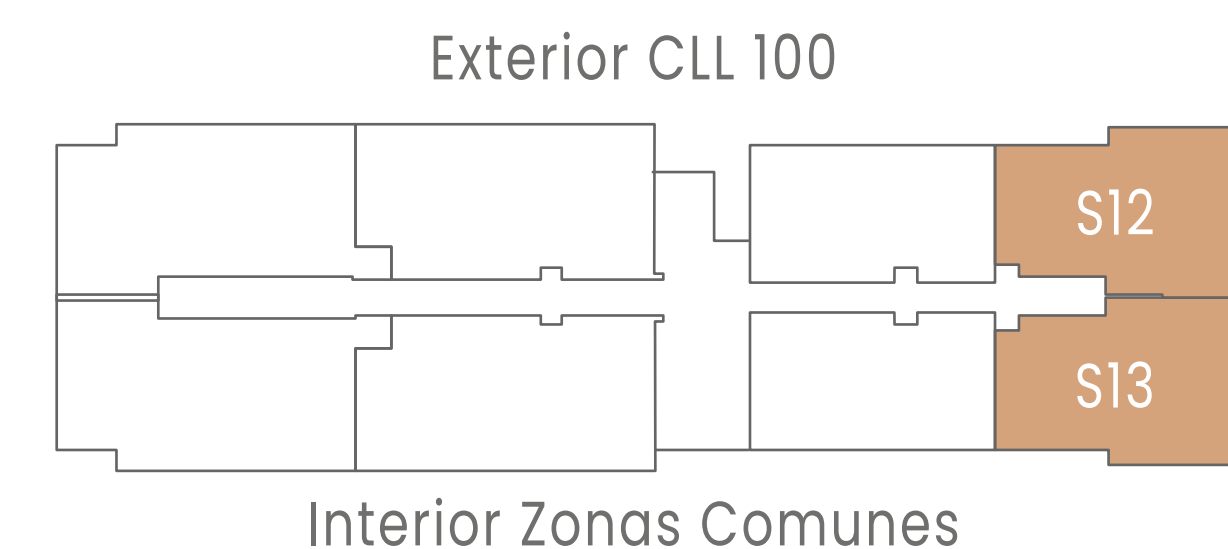

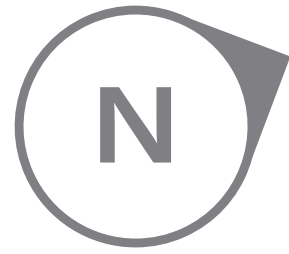

TIPO A
Opción Estudio
Torre 2 | Series 12 y 13
Área construida: 83,76* m²
Área privada: 78,35* m²

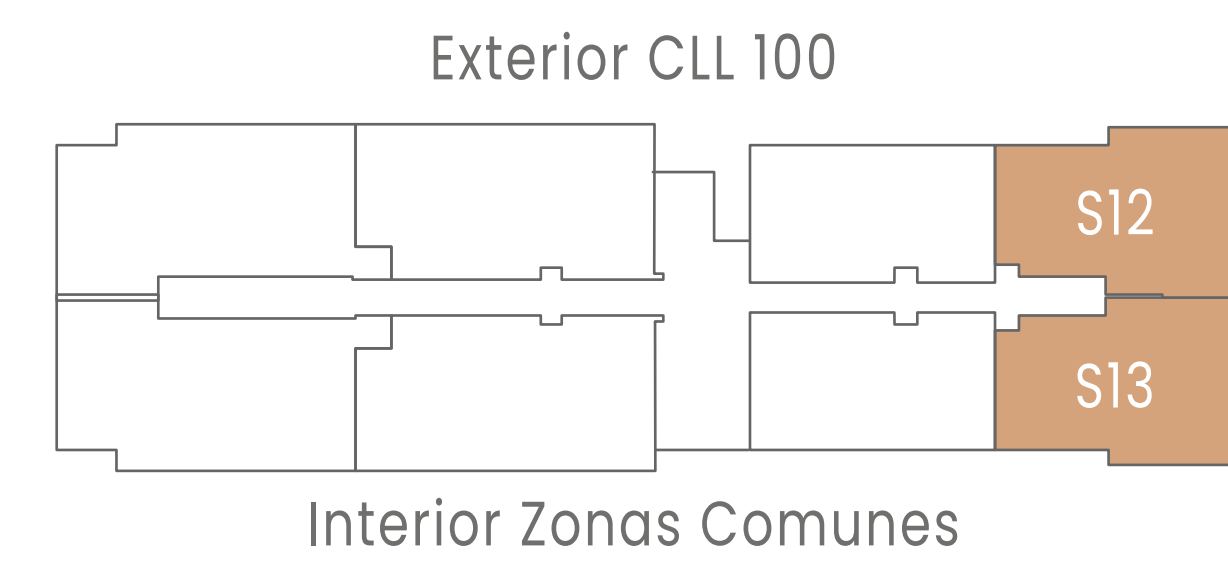



ACCESO



TIPO D

Opción Balcón

Torre 2 | Series 7 y 10

Área construida: 93,08* m²

Área privada: 88,09* m²

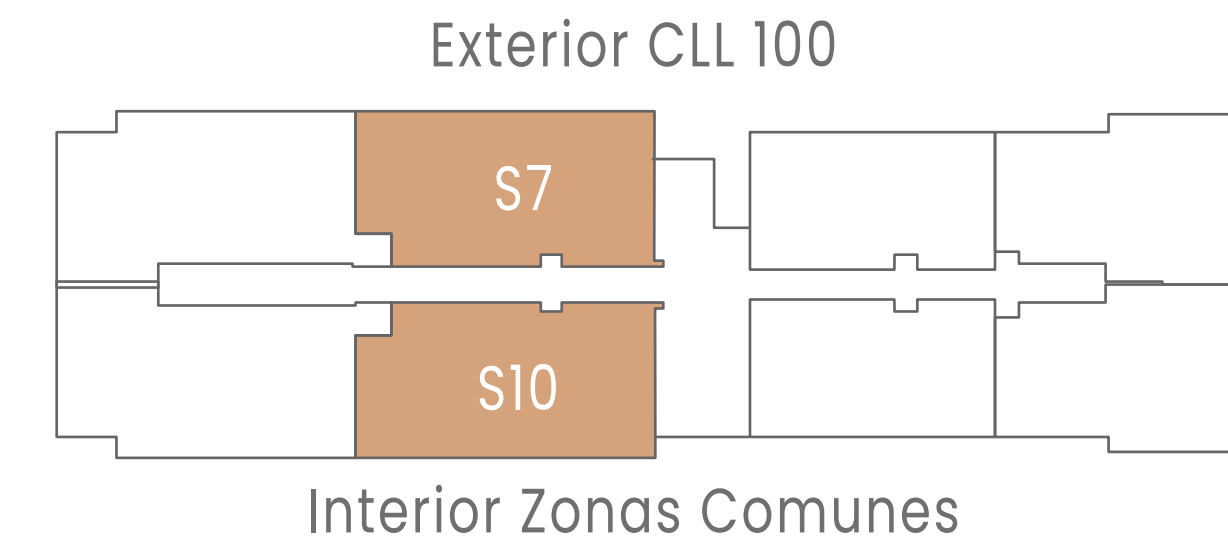



TIPO E
Opción Alcoba de Servicio
Torre 2 | Series 8 y 9
Área construida: 102,80* m²
Área privada: 94,82* m²

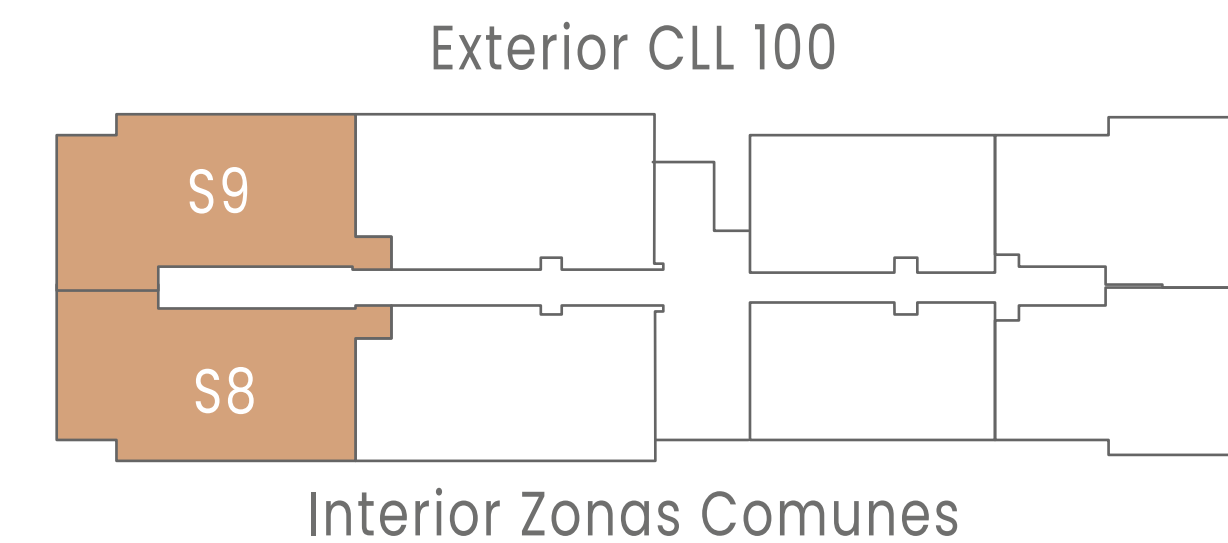



TIPO E
Opción Estudio
Torre 2 | Series 8 y 9
Área construida: 102,80* m²
Área privada: 95,82* m²

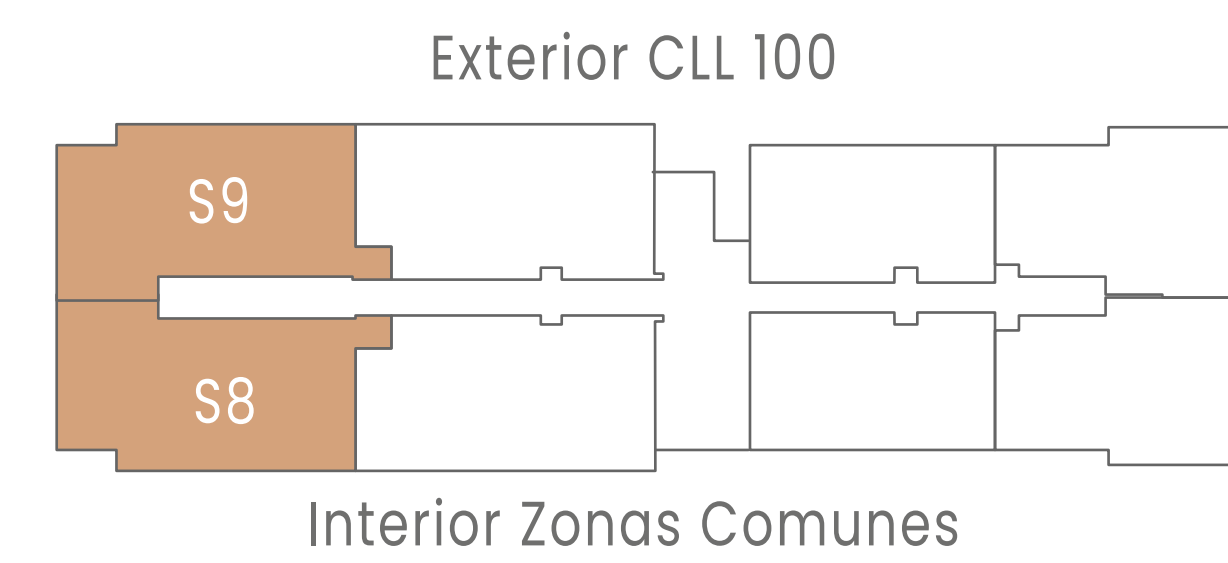

“Este plano contiene ilustraciones que son interpretación artística, no comprometen a la sociedad constructora. Su diseño definitivo corresponde a los planos aprobados por la curaduría urbana. *Áreas aproximadas.”

316 478 9720
riverpalms@londonogomez.com

DESARROLLADO POR: LONDOÑO GÓMEZ SAS. PROYECTO DESARROLLADO POR ETAPAS - ZONAS COMUNES ENTREGADAS POR ETAPAS. Especificaciones más detalladas en la página www.londonogomez.com. Todas las imágenes de esta pieza publicitaria podrán tener variaciones posteriores a su publicación; sugerimos corroborar con la sala de ventas antes de suscribir un contrato con la sociedad promotora. Precio sujeto a cambio sin previo aviso. Fecha de publicación: Julio 2022 *Aplican términos y condiciones.

